

## Small Diameter Indexable End-mill

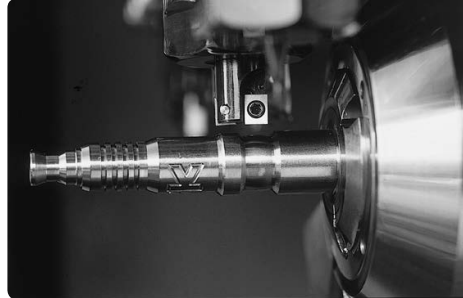

### Features

- Install a .787" (20mm) end mill in a ER16 collet
- Just rotate inserts to index. No need to make any adjustments
- High quality surface finish, as low as 1um (Rz) when using wiper inserts
- Corner radius as small as .002" available on inserts
- In addition to D cut, ramp machining can be performed \*

\* A combination of single-blade type endmills and inserts with center blade is required

### Inserts

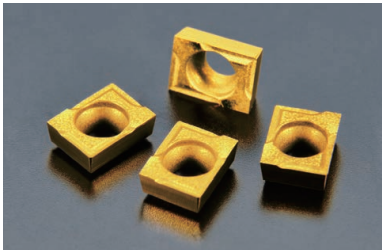

### Wiper

- Excellent surface finish obtained with wiper insert

### Chipbreaker

- Less tool pressure with chipbreaker

### 45° Chamfer

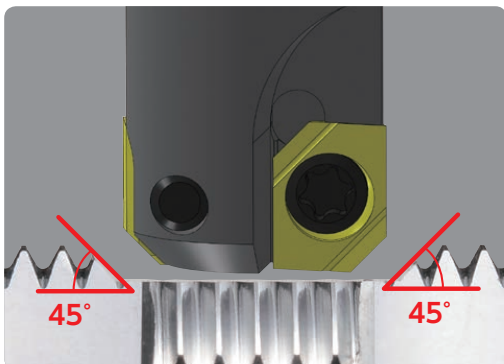

Chamfered surface finish insert	
S45C	
310 SFM	
.0056 IPR	
.039 DOC	
WET	
<b>NTK : QM3 C45</b>	700 pcs
Competitor's solid endmill	500 pcs

# S-MILL / Solid Carbide End-mill



## Features

- The tools sharpness creates a remarkable finish on machined surface
- 2, 3, and 4 flute designs with a selection of diameters to cover a variety of applications (2 flute available in 2mmφ)
- 40, 45, and 50 mm lengths ideal for automatic lathes
- AC3 grade - Micro-grain carbide + Thin TiACrN-TiAlN coat

### Two style



### 3 Flute Options



### Field Result

316 SS (D-cut) φ6mm-2 flute	
3,200 rpm	
5.5 IPM	
.024 DOC	
WET	
<b>NTK : S-MILL</b>	12,000 pcs/corner+α
Competitor's solid endmill	10,000 pcs/corner
<small>The competitor's end mill showed an obvious decrease in surface finish quality as it reached the end of its tool life. NTK's S-MILL maintained a quality surface finish throughout the extent of its longer tool life.</small>	

1045 (AF 8mm HEX) φ6mm-2 flute	
2,600 rpm	
18.9 IPM	
.039 DOC	
WET	
<b>NTK : S-MILL</b>	70 pcs/corner+α
Competitor's solid endmill	50 pcs/corner
<small>The S-MILL sharpness reduces the occurrence of burrs and tool life is increased; clear improvements over the competitor's tool. The sharp cutting edge also produces noticeably less sound than the current tooling.</small>	



## NTK Cutting Tools USA

a division of NGK SPARK PLUGS (U.S.A), INC.  
46929 Magellan Drive, Wixom, MI 48393, U.S.A.

www.ntkcuttingtools.com  
youtube.com/NTKCUTTINGTOOLS

### DISTRIBUTED BY

